

Modelarea mecanica a unui sistem cama-tachet in vederea analizei dinamice

Material pentru cursul Simularea sistemelor Electro-Mecanice
Dr.ing.Cristian Moldovan

Material preluat din cartea

The Dynamic Synthesis, Analysis, And Design Of Modeled Cam Systems,

autor Delbert Tesar, Gary Matthew, editor Lexington Books, 1976

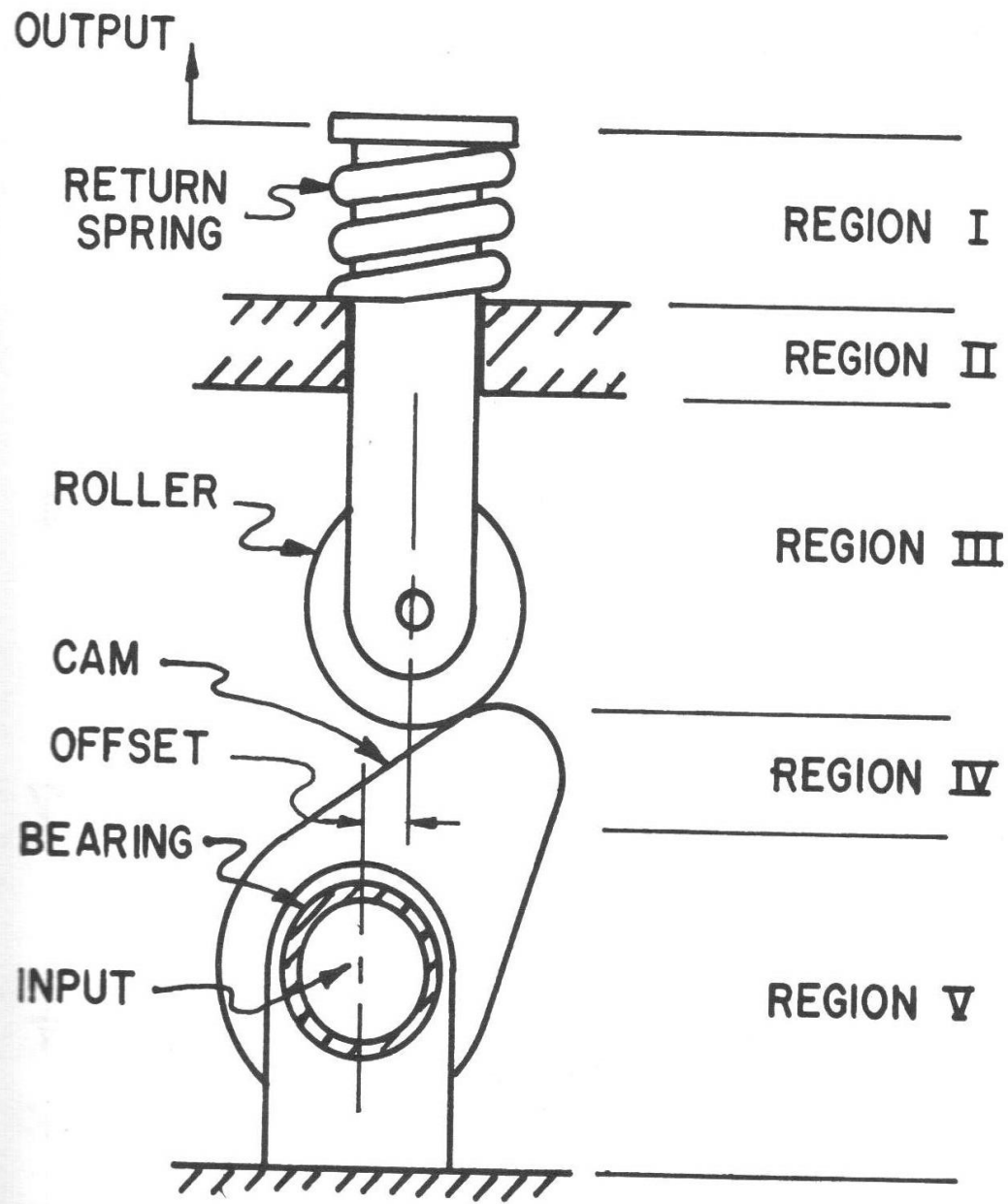

Figure 1-2. A Typical Cam System.

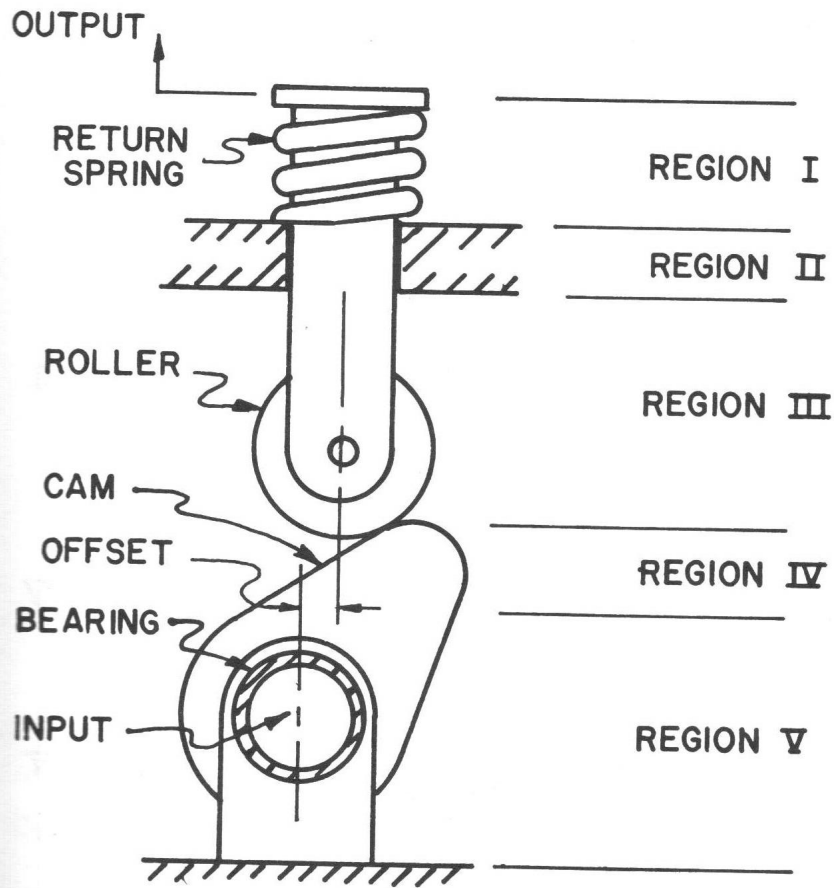

Figure 1-2. A Typical Cam System.

-Apar elemente discrete,
tip arc, amortizor

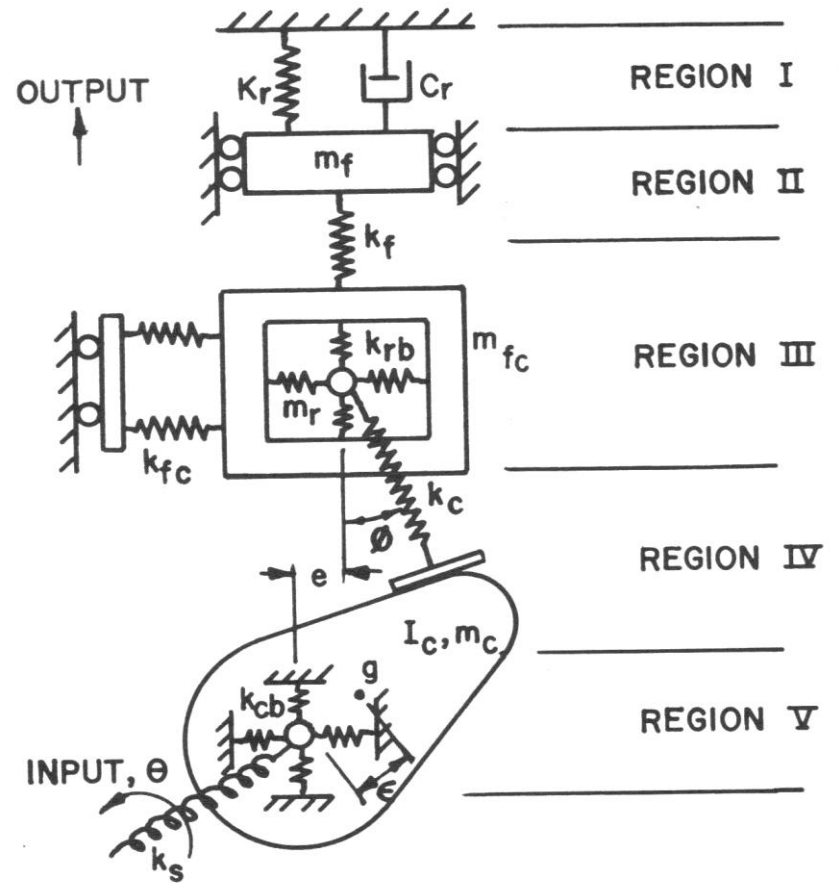

Figure 1-3. A Possible System Model.

